

**LIQUID CHROMATOGRAPHY - MASS SPECTROMETRY AND ITS APPLICATIONS**

Renuka Jajikore*, G. Ushasree, A. Ajitha, V. Umamaheswararao

Department of Pharmaceutical Analysis and Quality Assurance, CMR College of Pharmacy, Secunderabad, India

***Corresponding author e-mail:** renuka.jajikore164@gmail.com**ABSTRACT**

Liquid chromatography is a fundamental separation technique in the life sciences and related fields of chemistry. An LC-MS is an HPLC system with a mass spec detector. Liquid chromatography-mass spectrometry is now a routine technique with the development of electrospray ionisation providing a simple and robust interface. It can be applied to a wide range of biological molecules and the use of tandem MS and stable isotope internal standards allows highly sensitive and accurate assays to be developed although some method optimisation is required to minimise ion suppression effects.

Keywords: Liquid chromatography, mass spectrometers, electrospray ionisation**INTRODUCTION**

Liquid chromatography is a fundamental separation technique in the life sciences and related fields of chemistry. Unlike gas chromatography, which is unsuitable for non-volatile and thermally fragile molecules, liquid chromatography can safely separate a very wide range of organic compounds, from small-molecule drug metabolites to peptides and proteins.

Traditional detectors for liquid chromatography include refractive index, electrochemical, fluorescence, and ultraviolet-visible (UV-Vis) detectors. Some of these generate two-dimensional data; that is, data representing signal strength as a function of time. Others, including fluorescence and diode array UV-Vis detectors, generate three-dimensional data. Three-dimensional data include not only signal strength but spectral data for each point in time. Mass spectrometers also generate three-dimensional data. In addition to signal strength, they generate mass spectral data that can provide valuable information about the molecular weight, structure, identity, quantity, and purity of a sample. Mass spectral data add specificity that increases confidence in the results of both qualitative and quantitative analyses.

For most compounds, a mass spectrometer is more sensitive and far more specific than all other LC detectors. It can analyze compounds that lack a suitable chromophore. It can also identify components in unresolved chromatographic peaks, reducing the need for perfect chromatography. Mass spectral data complements data from other LC detectors. While two compounds may have similar UV spectra or similar mass spectra, it is uncommon for them to have both. The two orthogonal sets of data can be used to confidently identify, confirm, and quantify compounds.

Some mass spectrometers have the ability to perform multiple steps of mass spectrometry on a single sample. They can generate a mass spectrum, select a specific ion from that spectrum, fragment the ion, and generate another mass spectrum; repeating the entire cycle many times. Such mass spectrometers can literally deconstruct a complex molecule piece by piece until its structure is determined.

INSTRUMENTATION

Mass spectrometers work by ionizing molecules and then sorting and identifying the ions according to their mass-to-charge (m/z) ratios. Two key components in this process are the ion source, which

generates the ions, and the mass analyzer, which sorts the ions. Several different types of ion sources are commonly used for LC/MS. Each is suitable for different classes of compounds. Several different types of mass analyzers are also used. Each has advantages and disadvantages depending on the type of information needed.

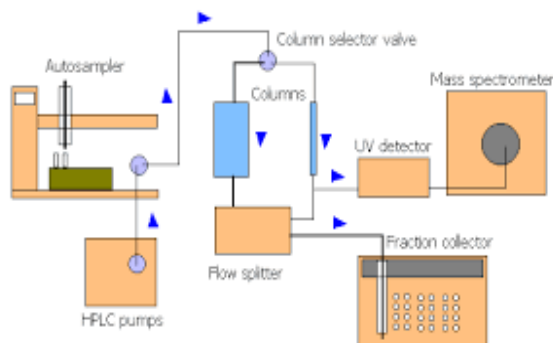

Fig 1 : Instrumentation

Ion Sources

Much of the advancement in LC/MS over the last ten years has been in the development of ion sources and techniques that ionize the analyte molecules and separate the resulting ions from the mobile phase. Earlier LC/MS systems used interfaces that either did not separate the mobile phase

molecules from the analyte molecules (direct liquid inlet, thermo spray) or did so before ionization (particle beam). The analyte molecules were then ionized in the mass spectrometer under vacuum, often by traditional electron ionization. These approaches were successful only for a very limited number of compounds. The introduction of atmospheric pressure ionization (API) techniques greatly expanded the number of compounds that can be successfully analyzed by LC/MS. In atmospheric pressure ionization, the analyte molecules are ionized first, at atmospheric pressure. The analyte ions are then mechanically and electrostatically separated from neutral molecules. Common atmospheric pressure ionization techniques are:

- Electro spray ionization (ESI)
- Atmospheric pressure chemical ionization (APCI)
- Atmospheric pressure photo ionization (APPI)

Electro spray relies in part on chemistry to generate analyte ions in solution before the analyte reaches the mass spectrometer. The LC eluent is sprayed (nebulized) into a chamber at atmospheric pressure in the presence of a strong electrostatic field and heated drying gas. The electrostatic field causes further dissociation of the analyte molecules. The heated drying gas causes the solvent in the droplets to evaporate. As the droplets shrink, the charge

concentration in the droplets increases. Eventually, the repulsive force between ions with like charges exceeds the cohesive forces and ions are ejected (desorbed) into the gas phase. These ions are attracted to and pass through a capillary sampling orifice into the mass analyzer.

Some gas-phase reactions, mostly proton transfer and charge exchange, can also occur between the time ions are ejected from the droplets and the time they reach the mass analyzer. Electrospray is especially useful for analyzing large biomolecules such as proteins, peptides, and oligonucleotides, but can also analyze smaller molecules like benzodiazepines and sulfated conjugates. Large molecules often acquire more than one charge. Thanks to this multiple charging, electrospray can be used to analyze molecules as large as 150,000 u even though the mass range (or more accurately mass-to-charge range) for a typical LC/MS instruments is around 3000 m/z. For example: $100,000 \text{ u} / 10 z = 1,000 \text{ m/z}$ When a large molecule acquires many charges, a mathematical process called deconvolution is often used to determine the actual molecular weight of the analyte.

Atmospheric pressure chemical ionization

In APCI, the LC eluent is sprayed through a heated (typically 250°C – 400°C) vaporizer at atmospheric pressure. The heat vaporizes the liquid. The resulting gas-phase solvent molecules are ionized by electrons discharged from a corona needle. The solvent ions then transfer charge to the analyte molecules through chemical reactions (chemical ionization). The analyte ions pass through a capillary sampling orifice into the mass analyzer. APCI is applicable to a wide range of polar and nonpolar molecules. It rarely results in multiple charging so it is typically used for molecules less than 1,500 u. Due to this, and because it involves high temperatures, APCI is less well-suited than electrospray for analysis of large biomolecules that may be thermally unstable. APCI is used with normal-phase chromatography more often than electrospray is because the analytes are usually nonpolar.

Atmospheric pressure photoionization

Atmospheric pressure photoionization (APPI) for LC/MS is a relatively new technique. As in APCI, a vaporizer converts the LC eluent to the gas phase. A discharge lamp generates photons in a narrow range of ionization energies. The range of energies is carefully chosen to ionize as many analyte molecules as possible while minimizing the ionization of solvent molecules. The resulting ions pass through a capillary sampling orifice into the mass analyzer. APPI is applicable to many of the same compounds that are typically analyzed by APCI. It shows

particular promise in two applications, highly nonpolar compounds and low flow rates

Mass Analyzers

Although in theory any type of mass analyzer could be used for LC/MS, four types:

- Quadrupole
- Time-of-flight
- Ion trap
- Fourier transform-ion cyclotron resonance (FT-ICR or FT-MS)

are used most often. Each has advantages and disadvantages depending on the requirements of a particular analysis.

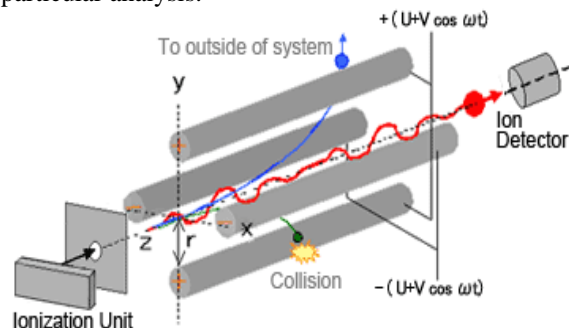

Fig 2: Quadrupole

Quadrupole

A quadrupole mass analyzer consists of four parallel rods arranged in a square. The analyte ions are directed down the center of the square. Voltages applied to the rods generate electromagnetic fields. These fields determine which mass-to-charge ratio of ions can pass through the filter at a given time. Quadrupoles tend to be the simplest and least expensive mass analyzers. Quadrupole mass analyzers can operate in two modes:

- Scanning (scan) mode
- Selected ion monitoring (SIM) mode

In scan mode, the mass analyzer monitors a range of mass-to-charge ratios. In SIM mode, the mass analyzer monitors only a few mass-to-charge ratios. SIM mode is significantly more sensitive than scan mode but provides information about fewer ions. Scan mode is typically used for qualitative analyses or for quantitation when all analyte masses are not known in advance. SIM mode is used for quantitation and monitoring of target compounds.

Time-of-flight

In a time-of-flight (TOF) mass analyzer, a uniform electromagnetic force is applied to all ions at the same time, causing them to accelerate down a flight tube. Lighter ions travel faster and arrive at the detector first, so the mass-to-charge ratios of the ions are determined by their arrival times. Time-of-flight

mass analyzers have a wide mass range and can be very accurate in their mass measurements.

Ion trap

An ion trap mass analyzer consists of a circular ring electrode plus two end caps that together form a chamber. Ions entering the chamber are “trapped” there by electromagnetic fields. Another field can be applied to selectively eject ions from the trap. Ion traps have the advantage of being able to perform multiple stages of mass spectrometry without additional mass analyzers.

Fourier transform-ion cyclotron resonance (FT-ICR)

An FT-ICR mass analyzer (also called FT-MS) is another type of trapping analyzer. Ions entering a chamber are trapped in circular orbits by powerful electrical and magnetic fields. When excited by a radio-frequency (RF) electrical field, the ions generate a time-dependent current. This current is converted by Fourier transform into orbital frequencies of the ions which correspond to their mass-to-charge ratios. Like ion traps, FT-ICR mass analyzers can perform multiple stages of mass spectrometry without additional mass analyzers. They also have a wide mass range and excellent mass resolution. They are, however, the most expensive of the mass analyzers.

Collision-Induced Dissociation and Multiple-Stage MS

The atmospheric pressure ionization techniques discussed are all relatively “soft” techniques. They generate primarily:

- Molecular ions M^+ or M^-
- Protonated molecules $[M + H]^+$
- Simple adduct ions $[M + Na]^+$
- Ions representing simple losses such as the loss of a water $[M + H - H_2O]^+$

The resulting molecular weight information is very valuable, but complementary structural information is often needed. To obtain structural information, analyte ions are fragmented by colliding them with neutral molecules in a process known as collision-induced dissociation (CID) or collisionally activated dissociation (CAD). Voltages are applied to the analyte ions to add energy to the collisions and create more fragmentation.

CID in single-stage MS

CID is most often associated with multistage mass spectrometers where it takes place between each stage of MS filtering, but CID can also be accomplished in single-stage quadrupole or time-of-flight mass spectrometers. In single-stage mass

spectrometers, CID takes place in the ion source and is thus sometimes called source CID or in-source CID. Analyte (precursor) ions are accelerated and collide with residual neutral molecules to yield fragments called product ions. The advantage of performing CID in singlestage instruments is their simplicity and relatively low cost. The disadvantage is that ALL ions present are fragmented. There is no way to select a specific precursor ion so there is no sure way to determine which product ions came from which precursor ion. The resulting spectra may include mass peaks from background ions or coeluting compounds as well as those from the analyte of interest. This tradeoff may be acceptable when analyzing relatively pure samples, but does not give good results if chromatographic peaks are not well resolved or background levels are high.

CID and multiple-stage

MS Multiple-stage MS (also called tandem MS or MS/MS or MSⁿ) is a powerful way to obtain structural information. In triple-quadrupole or quadrupole/quadrupole/time-of-flight instruments (see Figure 16), the first quadrupole is used to select the precursor ion. CID takes place in the second stage (quadrupole or octopole), which is called the collision cell.

The third stage (quadrupole or TOF) then generates a spectrum of the resulting product ions. It can also perform selected ion monitoring of only a few product ions when quantitating target compounds. In ion trap and FT-ICR mass spectrometers, all ions except the desired precursor ion are ejected from the trap. The precursor ion is then energized and collided to generate product ions. The product ions can be ejected to generate a mass spectrum, or a particular product ion can be retained and collided to obtain another set of product ions. This process can be sequentially automated so that the most abundant ion(s) from each stage of MS are retained and collided. This is a very powerful technique for determining the structure of molecules. It is also a powerful technique for obtaining peptide mass information that relates to the sequence of amino acids in a peptide. A major advantage of multiple-stage MS is its ability to use the first stage of MS to discard nonanalyte ions. Sample cleanup and chromatographic separation become much less critical. With relatively pure samples, it is quite common to do away with chromatographic separation altogether and infuse samples directly into the mass spectrometer to obtain product mass spectra for characterization or confirmation.

Adapting LC Methods

Early LC/MS systems were limited by fundamental issues like the amount of LC eluent the mass spectrometer could accept. Significant changes to LC methods were often required to adapt them to MS detectors. Modern LC/MS systems are more versatile. Many mass spectrometers can accept flow rates of up to 2 ml/min. With minor modifications, the same instruments can also generate good results at microliter and nanoliter flow rates. Ion sources with orthogonal (off-axis) nebulizers are more tolerant of nonvolatile buffers and require little or no adjustment, even with differing solvent compositions and flow rates. Changes to LC methods required for modern LC/MS systems generally involve changes in sample preparation and solution chemistry to:

- Ensure adequate analyte concentration
- Maximize ionization through careful selection of solvents and buffers
- Minimize the presence of compounds that compete for ionization or suppress signal through gas-phase reactions

Sample preparation

Sample preparation generally consists of concentrating the analyte and removing compounds that can cause background ions or suppress ionization. Examples of sample preparation include:

- On-column concentration to increase analyte concentration
- Desalting to reduce the sodium and potassium adduct formation that commonly occurs in electrospray
- Filtration to separate a lowmolecular-weight drug from proteins in plasma, milk, or tissue

Ionization chemistry

Because formation of analyte ions in solution is essential to achieving good electrospray results, careful attention must be paid to proper solution chemistry. For electrospray:

- Select more volatile buffers to reduce the buildup of salts in the ion source
- Adjust solvent pH according to the polarity of ions desired and the pH of the sample
- Use solvents that have low heats of vaporization and low surface tensions to enhance ion desorption
- Make sure that gas-phase reactions do not neutralize ions through proton transfer or ion pair reactions

If pH adjustments interfere with proper chromatography, postcolumn modification of the solvent may be a good solution. This can improve MS response without compromising chromatography. Solution chemistry is less critical for APCI operation because ionization occurs in the gas phase, not the liquid phase, but solvent selection can still have a significant effect on APCI analyte signal response.

- Select more volatile solvents

- Select solvents with a lower charge affinity than the analyte
 - Protic solvents generally work better than nonprotic solvents for positive ion mode
 - For negative ionization, solvents that readily capture an electron must be used
 - Ammonium salts in the mobile phase can cause ammonium adduct formation
- Vaporizer temperature also affects APCI ionization results. The temperature must be hot enough to vaporize the solvent but not so hot as to cause thermal degradation of the analyte molecules

Capillary LC/MS and CE/MS

Capillary LC and capillary electrophoresis (CE) are commonly used alongside HPLC. Capillary LC at microliter to nanoliter flow rates often provides better sensitivity than conventional flow rates for extremely small sample quantities. It is commonly used for protein and peptide analysis but has also proven very useful for the analysis of small quantities of drugs. Capillary electrophoresis (CE) is a technique with a high separation efficiency and the added benefit of being able to handle very complex matrices. It has proven useful for such diverse samples as: peptides, drugs of abuse, drugs in natural products, flavanoids, and aromatic amines. With specialized nebulizers and method adjustments, electrospray ionization can be used for both capillary LC/MS and CE/MS. The mass spectrometry benefits of selectivity and sensitivity are available to both of these separation techniques.

APPLICATIONS

LC/MS is suitable for many applications, from pharmaceutical development to environmental analysis. Its ability to detect a wide range of compounds with great sensitivity and specificity has made it popular in a variety of fields.

Molecular Weight Determination

One fundamental application of LC/MS is the determination of molecular weights. This information is key to determining identity.

Differentiation of similar octapeptides

The only difference in the sequence is at the C-terminus where one peptide has threonine and the other has threonine amide. The smaller fragments are identical in the two spectra, indicating that large portions of the two peptides are very similar. The larger fragments contain the differentiating peptides.

Determining the molecular weight of green fluorescent protein

Green fluorescent protein (GFP) is a 27,000-Dalton protein with 238 amino acids. It emits a green light when excited by ultraviolet light. During electrospray ionization, GFP acquires multiple charges. This allows it to be analyzed by a mass spectrometer with a relatively limited mass (mass-to-charge) range. Mass deconvolution is then used to determine the molecular weight of the protein. The upper part of the display in Figure 23 shows the full scan mass spectrum of GFP. The pattern of mass spectral peaks is characteristic of a multiply charged analyte. Each peak represents the molecule with a different number of charges. The lower display is a deconvoluted mass spectrum generated by the data system for the singly charged analyte.

Structural Determination

Another fundamental application of LC/MS is the determination of information about molecular structure. This can be in addition to molecular weight information or instead of molecular weight information if the identity of the analyte is already known.

Structural determination of ginsenosides using MSⁿ analysis

Ginseng root, a traditional Chinese herbal remedy, contains more than a dozen biologically active saponins called ginsenosides. Since most ginsenosides contain multiple oligosaccharide chains at different positions in the molecule, structural elucidation of these compounds can be quite complicated. MSⁿ analysis in an ion trap mass spectrometer permits multiple stages of precursor ion isolation and fragmentation. This stepwise fragmentation permits individual fragmentation pathways to be followed and provides a great deal of structural information. Figure 24 shows the full scan mass spectrum from a direct infusion of the ginsenoside Rb1. The most prominent feature is the sodium adduct ion [M + Na]⁺ at m/z 1131.7. MS/MS of m/z 1131.7 yields a product ion at m/z 789.7 corresponding to cleavage of a single glycosidic bond (Figure 25). Subsequent isolation and fragmentation of m/z 789.7 (Figure 26) yields two products: a more abundant ion at m/z 365.1 corresponding to loss of the oligosaccharide chain (-Glc 2 -Glc), and a less abundant ion at m/z 627.5 representing the loss of a deoxyhexose sugar.

Pharmaceutical Applications

Rapid chromatography of benzodiazepines

The information available in a mass spectrum allows some compounds to be separated even though they

are chromatographically unresolved. In this example, a series of benzodiazepines was analyzed using both UV and MS detectors. The UV trace could not be used for quantitation, but the extracted ion chromatograms from the MS could be used. The mass spectral information provides additional confirmation of identity. Chlorine has a characteristic pattern because of the relative abundance of the two most abundant isotopes. The triazolam spectrum shows that triazolam has two chlorines and the diazepam spectrum shows that diazepam has only one.

Identification of bile acid metabolites

The MSn capabilities of the ion trap mass spectrometer make it a powerful tool for the structural analysis of complex mixtures. Intelligent, data-dependent acquisition techniques can increase ion trap effectiveness and productivity. They permit the identification of minor metabolites at very low abundances from a single analysis. One application is the identification of metabolic products of drug candidates.

This example uses the in vitro incubation of the bile acid deoxycholic acid with rat liver microsomes to simulate metabolism of a drug candidate. Intelligent, data-dependent acquisition was used to select the two most abundant, relevant ions in each MS scan. These precursor ions were automatically fragmented and full scan product ion spectra collected. Figure 28A shows the base peak chromatogram. Figure 28B shows the extracted ion chromatogram of the [M-H]⁻ ion at m/z 407

corresponding to a predicted minor metabolite (cholic acid) that eluted at 9.41 minutes. The full scan MS/MS product spectrum (Figure 28C) from the ion at m/z 407 confirms the identity. Significant time was saved because the confirming MS/MS product ion spectra were acquired automatically in the same run as the full scan MS data.

Biochemical Applications

Rapid protein identification using capillary LC/MS/MS and database searching

Traditional methods of protein identification generally require the isolation of individual proteins by two-dimensional gel electrophoresis. The combination of capillary LC/MS/MS with intelligent, data-dependent acquisition and probability-based database searching makes it possible to rapidly identify as many as 100 proteins in a single analysis. In this example, a capillary LC and ion trap mass spectrometer were used to acquire data from a mixture of five tryptically digested proteins at a concentration of 1 pmol/μl each (Figure 29). Using intelligent, automated data-dependent acquisition, a

full scan product ion (MS/MS) spectrum was acquired from the most abundant relevant ion in each mass scan throughout the entire run. All MS and MS/MS data were acquired from a single analysis.

Protein identification was accomplished using MASCOT software that correlated the uninterpreted MS/MS data with sequences in a database. Figure 30 demonstrates the excellent match between the observed MS/MS spectrum from the most abundant ion (m/z 807.2) in the chromatographic peak at 17.55 minutes and the theoretical y-ion series predicted for a tryptic peptide from human apolipoprotein, one of the proteins in the sample mixture.

Clinical Applications

High-sensitivity detection of trimipramine and thioridazine

For most compounds, MS is more sensitive than other LC detectors. Trimipramine is a tricyclic antidepressant with sedative properties. Thioridazine is a tranquilizer. Figure 31 shows these compounds in a urine extract at a level that could not be detected by UV. To get the maximum sensitivity from a single-quadrupole mass spectrometer, the analysis was done by selected ion monitoring.

Food Applications

Identification of aflatoxins in food

Aflatoxins are toxic metabolites produced in foods by certain fungi. Figure 32 shows the total ion chromatogram from a mixture of four aflatoxins. Even though they are structurally very similar, each aflatoxin can be uniquely identified by its mass spectrum.

Determination of vitamin D3 in poultry feed supplements using MS3

Vitamin D is an essential constituent in human and animal nutrition. Livestock diets deficient in vitamin D can cause growth abnormalities. Traditional GC/MS analysis methods for vitamin D3 in feed extracts require extensive and time-consuming sample preparation and derivatization prior to analysis. Atmospheric pressure chemical ionization with ion trap detection provides a sensitive analytical method without the need for extensive sample preparation and derivatization. Further, the multiple-stage MS capability of the ion trap eliminates the need for chromatographic separation, greatly speeding analyses. Flow injection analysis of a poultry feed extract yields a peak at m/z 385 suggesting the presence of vitamin D3. Isolation and fragmentation of the precursor ion at m/z 385 is inconclusive. The full scan product ion spectrum shows a prominent peak at m/z 367 representing the loss of a single water molecule but little other fragmentation.

Environmental Applications

Detection of phenylurea herbicides

Many of the phenylurea herbicides are very similar and difficult to distinguish with a UV detector (Figure 36). Monuron and diuron have one benzene ring and differ by a single chlorine. Chloroxuron has two chlorines and a second benzene ring attached to the first by an oxygen. The UV-Vis spectra are similar for diuron and monuron, but different for chloroxuron. When analyzed using electrospray ionization on an LC/MS system, each compound has a uniquely identifiable mass spectrum.

Detection of low levels of carbaryl in food

Pesticides in foods and beverages can be a significant route to human exposure. Analysis of the carbamate pesticide carbaryl in extracts of whole food by ion trap LC/MS/MS proved more specific than previous analyses by HPLC fluorescence and single-quadrupole mass spectrometry. The protonated carbaryl molecule (m/z 202) was detected in full scan mode using positive ion electrospray. A product ion at m/z 145 (Figure 37) generated by collision-induced dissociation provided confirmation of carbaryl and was used for subsequent quantitative analysis.

Ion trap analysis was more sensitive than previous analysis using a single-quadrupole mass spectrometer operating in scanning mode and more sensitive than fluorescence detection. Ion trap LC/MS/MS also confirmed false positives in the HPLC fluorescence

analysis caused by a coeluting compound. Based on the MS/MS spectrum of the coeluting compound, a possible structure was assigned

CE/MS Applications

Analysis of peptides using CE/MS/MS

Capillary electrophoresis (CE) is a powerful complement to liquid chromatography. Different selectivity and higher chromatographic resolution are its biggest advantages when analyzing clean samples such as synthetic peptides. When analyzing ppm-levels of analytes in complex matrices, minimal sample preparation and short analysis times enable high throughput.

CE/MS with an ion trap mass spectrometer is demonstrated using a standard peptide mix. The data-dependent acquisition capability of the ion trap triggers MS/MS on the most intense ion in each MS scan. Figure 39 shows total ion electropherogram (TIE) and the base peak electropherogram (BPE). Drops in the TIE indicate where MS/MS spectra were acquired automatically. The averaged mass spectrum of peak 4 (Figure 40) shows a singly charged molecule with m/z of 574.3. This is confirmed as Met-enkephalin (molecular weight 573.7) by the examination of the MS/MS mass spectrum. The MS/MS spectrum shows all of the b- and y-series fragments within the scan range as well as fragments from other series.

REFERENCES

1. James J Pitt. Principles and Applications of Liquid Chromatography-Mass Spectrometry in Clinical Biochemistry. Clin Biochem Rev. 2009; 30(1): 19–34.
2. Fenn JB, Mann M, Meng CK, Wong SF, Whitehouse CM. Electrospray ionization for mass spectrometry of large biomolecules. Science. 1989;246:64–71.
3. The Nobel Prize in Chemistry. 2002. [(Accessed 23 November 2008)]. http://nobelprize.org/nobel_prizes/chemistry/laureates/2002/
4. Rashed MS, Bucknall MP, Little D, Awad A, Jacob M, Alamoudi M, et al. Screening blood spots for inborn errors of metabolism by electrospray tandem mass spectrometry with a microplate batch process and a computer algorithm for automated flagging of abnormal profiles. Clin Chem. 1997;43:1129–41.
5. Ho CS, Lam CWK, Chan MHM, Cheung RCK, Law LK, Lit LCW, et al. Electrospray ionisation mass spectrometry: principles and clinical applications. Clin Biochem Rev. 2003;24:3–12.
6. Kebarle P. A brief overview of the present status of the mechanisms involved in electrospray mass spectrometry. J Mass Spectrom. 2000;35:804–17.
7. Carr SA, Huddleston MJ, Bean MF. Selective identification and differentiation of N- and O-linked oligosaccharides in glycoproteins by liquid chromatography-mass spectrometry. Protein Sci. 1993;2:183–96.
8. Byrdwell WC. Atmospheric pressure chemical ionization mass spectrometry for analysis of lipids. Lipids. 2001;36:327–46.
9. Rosenberg E. The potential of organic (electrospray- and atmospheric pressure chemical ionisation) mass spectrometric techniques coupled to liquid-phase separation for speciation analysis. J Chromatogr A. 2003;1000:841–89.
10. Carvalho VM, Nakamura OH, Vieira JGH. Simultaneous quantitation of seven endogenous C-21 adrenal steroids by liquid chromatography tandem mass spectrometry in human serum. J Chromatogr B Analyt Technol Biomed Life Sci. 2008;872:154–61.